

NAME: _____

St. Francis High School

Algebra Basic Skills

Workbook

Use this workbook to help prepare for the Basic Skills test that will be given in the first week of school to all students enrolled in Geometry or Honors Geometry. Students enrolled in Algebra I, part 2 will be tested on skills 1, 2, 3, and 6.

Samples of the types of problems on the test are included, but if you are having trouble with any section more problems can be found by searching the internet or in workbooks available in bookstores. The test will be taken **WITHOUT** calculators so do these problems without one unless otherwise indicated. Answers are provided at the back of the workbook. Work through the practice sections during the summer.

A sample test is included. Take this sample test the week before schools starts and brush up on any sections that you found difficult. You will be asked to do extra work on the skills you do not successfully master. Good luck.

SKILL A1: SIGNED NUMBERS AND ORDER OF OPERATION

- **ADD** numbers with the **SAME SIGN** and keep the sign
- **ADD** numbers with **OPPOSITE SIGNS** and keep the sign of the number with the most distance from zero on the number line

Work the following problems. Try to check them on your calculator.

1. $-5 + 1$	2. $-6 + (-2)$	3. $-3 + 10$	4. $5 + (-3)$	5. $-15 + 13$	6. $0 + (-5)$
7. $-4 - 2$	8. $-5 - (-3)$	9. $12 - (-2)$	10. $0 - (-3)$	11. $-3 - (-3)$	12. $-4 - 3$
13. $-4 - (-4) - 4$	14. $-36 - 24 + 12$		15. $16 - (-21) - 13 - (-2)$		
16. $\frac{3}{5} - \left(-\frac{2}{5}\right)$	17. $2\frac{3}{7} - \left(-1\frac{4}{7}\right)$		18. $-\frac{13}{15} - \frac{2}{3}$		
19. $-1\frac{3}{5} - \frac{2}{5}$	20. $\frac{3}{5} - \left(-\frac{5}{2}\right)$		21. $\left(-\frac{2}{5}\right) - \left(-\frac{2}{5}\right)$		
22. Mom gave me \$10. I owed \$2.50 to my sister and \$3.75 to a friend. If I paid them what I owed, how much money was left for me?			23. On Jan. 1 Chicago got 6 inches of snow. Two days later 4.5 inches had melted. Another storm brought 2.75 inches on Jan. 6. How much snow was on the ground when that storm ended?		

- **MULTIPLY (or Divide)** numbers with the **SAME SIGN** and the answer is **POSITIVE**
- **MULTIPLY (or Divide)** numbers with **OPPOSITE SIGNS** and the answer is **NEGATIVE**

Work the following problems. Try to check them on your calculator.

24. $-2(-15)$	25. $-21 * 10$	26. $15 * -3$	27. $(-1.5)(-2)$	28. $-25 \div -5$	29. $(-4)(14)$
30. $(-3) \div (-6)$	31. $64 \div (-4)$	32. $(-1.2)^2$	33. $72 \div (-1.2)$	34. $(-360) \div (-12)$	35. $-12 * 3.2$
36. $\left(-\frac{3}{5}\right)\left(\frac{10}{9}\right)$		37. $(25.75)(-2)$		38. $\left(\frac{-3}{8}\right) \div \left(\frac{-15}{16}\right)$	
39. $\left(\frac{-6}{7}\right) \div \left(\frac{12}{5}\right)$		40. $\left(-1\frac{3}{5}\right)\left(\frac{1}{2}\right)$		41. $\left(-\frac{2}{5}\right) \div \left(\frac{10}{16}\right)$	
EVALUATE the following if $x = -2$ and $y = -3$					
42. $4x^2y$	43. $\frac{x+y}{xy}$	44. $-x - 2y$	45. $xy + x$	46. $3x - 2y$	

SKILL A2: TRANSLATING TO ALGEBRA

- English can be translated into Algebra. The hardest thing about doing word problems is taking the English words and translating them into mathematics. For example **more than** means to **add**, **less than** means to **subtract**, **double or twice** means to **multiply by 2**, “**is**” translates into an **equal sign**.
- Is less than** uses the $<$ symbol and **Is greater than** uses $>$
- Listed in the following table are some of the most common words used in word problems.

Addition	Subtraction	Multiplication	Division	Equals
<ul style="list-style-type: none"> ○ Increased by ○ More than ○ Combined together ○ Total ○ Sum ○ Added to ○ Plus 	<ul style="list-style-type: none"> ○ Decreased by ○ Minus, less ○ Less than ○ Fewer than ○ Difference between 	<ul style="list-style-type: none"> ○ Of ○ Times ○ Multiplied by ○ Product of ○ Factor of 	<ul style="list-style-type: none"> ○ Per ○ Divided by ○ Out of ○ Ratio of ○ Quotient of ○ Percent (divide by 100) 	<ul style="list-style-type: none"> ○ Is ○ Are ○ Gives ○ Yields

- Samples: 15 increased by a number: $15 + n$
the sum of 10 and a: $10 + a$
5 coins equal 50¢: $5c = 50$

Translate the following phrases into Algebra (Let n be a number):

1. 4 more than a number	2. 7 times a number	3. 3 less than a number
4. Twice a number	5. 6 less than a number	6. A number decreased by 10`
7. 3 more than m	8. The product of 2 and x	9. 3 increased by y
10. 4 more than 3 times z	11. 4 times a number decreased by 3	12. 4 less than twice a number
13. The difference between twice x and y	14. The quotient when x is divided by y	15. The sum of x and y divided by the difference of x and y
16. Mary has “p” number of pets. Write the expression stating that Jay has 1 pet less than twice the number Mary has.	17. Joan has \$5 more than Sue. If Sue has “S” dollars, write an expression for the amount of money Joan has	18. Bob had “R” problems right on the last test. Write an expression for the number Joe had right if he had 3 less than three times the number right than Bob had.
19. The sum of a number and its double is 45.	20. The product of a number and 2 is 12.	21. A number is less than 5.

SKILL A3 SOLVING LINEAR EQUATIONS WITH INTEGRAL COEFFICIENTS

SOLVE EACH EQUATION.

1. $3 + a = 11$	2. $x - 8 = 15$	3. $\frac{h}{4} = 13$
4. $4 = 8w$	5. $5y = 15$	6. $\frac{6x}{3} = 22$
7. $2x - 6 = 10$	8. $3k + 2k = 25$	9. $5d - 6 = -21$
10. $14x + 7 = 63$	11. $8g - 12g = 16$	12. $\frac{x}{2} + 8 = 14$
13. $5v - 7 + 2v = 35$	14. $3(x + 2) = 24$	15. $2x - 7x + 6 = 36$

16. $3a + (a + 4) = -8$	17. $7f + 2 = -34$	18. $4y - (y + 5) = 28$
19. $-(7x + 9) + 5x = 27$	20. $4 - 2(3x + 5) = 22$	21. $5 + 2(w - 6) = 3$
22. $4 = 16g - 3(g + 3)$	23. $5x + 8 = 2x - 13$	24. $4z - 16 = 2(3z - 6)$
25. $10f - 4 = -4f - 32$	26. $2u + 4 = (u - 4) + 3u$	27. $-3(-4d + 2) = 5(2d + 12)$
28. $3(2y - 1) = 5y + 5$	29. $32 + 2w = 5(w - 3)$	30. $8 - 4(2x + 15) = 30 + 2x$

SKILL A4 MONOMIAL & BINOMIAL OPERATIONS: ADD, SUBTRACT, MULTIPLY

SIMPLIFY

1. $3x + 2x^2 - 5x^2 + x$	2. $-4y - 3x - 2y + 5x$	3. $3(x - 2y) - (2x + y)$
4. $2x^2 + x(2x + 3)$	5. $3x^2 + x(5x - 2)$	6. $4x^2 + x(3x - 5)$
7. $6x - 2 - (7x + 3)$	8. $3x + 2 - (4x + 5)$	9. $4x - 3 - (x + 10)$
10. $2x(x^2 + 3)$	11. $3x(x^2 - 4)$	12. $4x(x^3 + 5)$
13. $(x^4)^2$	14. $(x^5)^3$	15. $(x^7)^4$

16. $(3x^4)^2$	17. $(3x^3)^3$	18. $(2x^5)^4$
19. $(x+2)(x-2)$	20. $(x+3)(x+4)$	21. $(x-4)(x-5)$
22. $(2x+3)(x+4)$	23. $(x-2)(3x+4)$	24. $(x-1)(x+3)$
25. $x(x+5)$	26. $3x^2 + x(2+3x)$	27. $6x-4-(3+4x)$
28. $3x(x^3-7)$	29. $(x+3)^2$	30. $(3x^4)^3$

SKILL A5 FACTORING: COMMON MONOMIAL; TRINOMIAL, LEAD COEFFICIENT OF ONE

FACTOR EACH POLYNOMIAL COMPLETELY:

1. $15x+27$	2. $6a^4-20a$	3. $63z+45$
4. $12m-9$	5. x^2-x^3	6. $12a^3-15a$
7. $-18x^2-6x$	8. $5c-c^2$	9. $80g^2-60g^5$
10. $2x^4-8x^3+10x^2$	11. $75n-30$	12. $-12y^3+24y$
13. $4v^4+20v^3-12v$	14. $32x^3+8x^2$	15. $10x^2+50x$

16. $x^2 + 5x + 6$	17. $y^2 + 9y + 18$	18. $a^2 + 16a + 63$
19. $d^2 - 13d + 12$	20. $w^2 - 12w + 20$	21. $x^2 + 11x + 30$
22. $x^2 + 6x + 9$	23. $m^2 + m - 56$	24. $z^2 - 3z - 18$
25. $h^2 - 6h - 16$	26. $k^2 - 5k - 36$	27. $r^2 + 3r - 10$
28. $g^2 - g - 30$	29. $x^2 - 49$	30. $a^2 - 9$

SKILL A6 GRAPHING LINEAR FUNCTIONS AND SLOPE

Slope: $m = \frac{y_2 - y_1}{x_2 - x_1}$ Slope is the change in y over the change in x . Since a HORIZONTAL line is flat, its

slope is ZERO and a VERTICAL line has NO SLOPE – it is too steep to measure.

Find the slope for the following sets of points.

1. $(3, -2)$ and $(5, 10)$	2. $(5, 0)$ and $(0, 5)$	3. $(5, -4)$ and $(7, -1)$
4. $(3, 7)$ and $(0, 4)$	5. $(2, 3)$ and $(4, -3)$	6. $(-1, -5)$ and $(3, -4)$
7. $(3, 5)$ and $(3, -2)$	8. $(4, -1)$ and $(6, -1)$	9. $(5, 3)$ and $(-5, -3)$

Slope Intercept Form: $y = mx + b$

m is slope and b is the y -intercept (where the line crosses the y -axis)

10. Graph the line if $b = 2$ and $m = \frac{2}{3}$

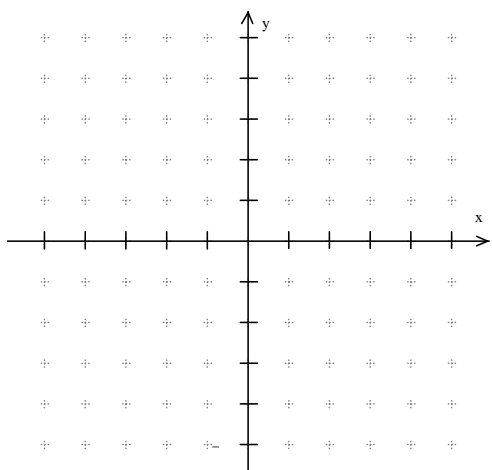

11. Graph the line if $b = -2$ and $m = \frac{-1}{3}$

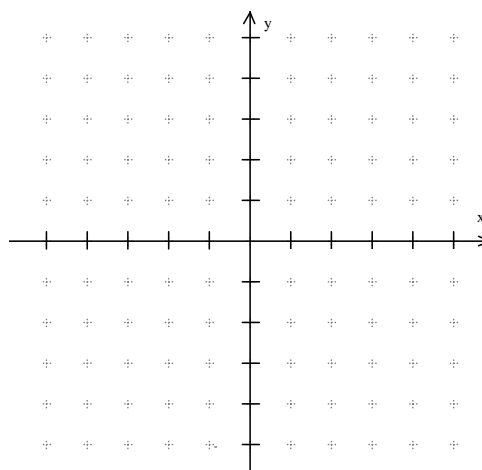

Given the following equation

$$y = 3x + 1$$

12. State the slope of the line and y-intercept

13. Graph the line determined by the equation

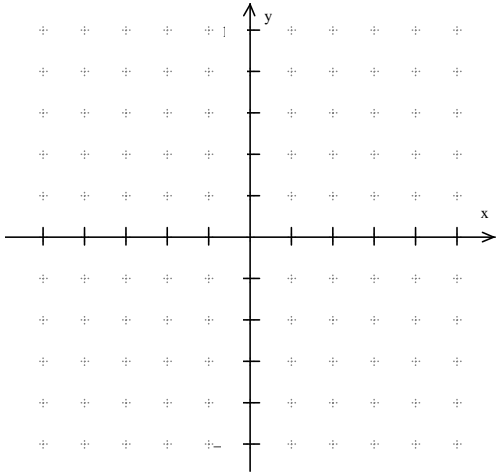

Given the following equation

$$y = -\frac{1}{2}x + 5$$

14. State the slope of the line and y-intercept

15. Graph the line determined by the equation

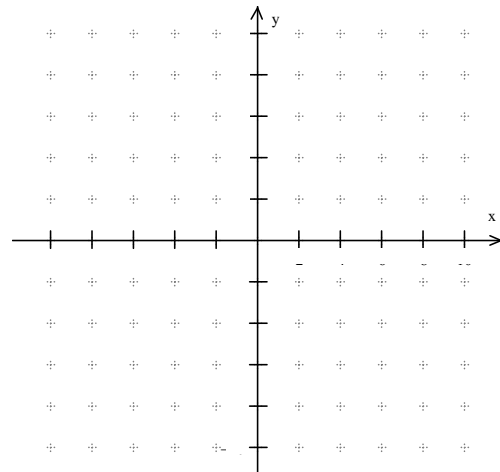

Given the following equation

$$3x + 2y = 4$$

16. State the slope of the line and y-intercept

17. Graph the line determined by the equation

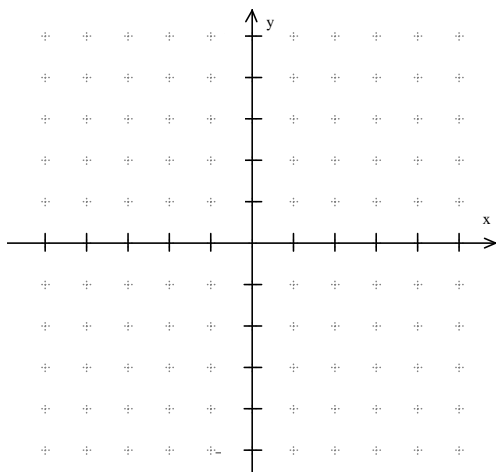

Given the following equation

$$2x + 3y + 4x - 5y = -8$$

18. State the slope of the line and y-intercept

19. Graph the line determined by the equation

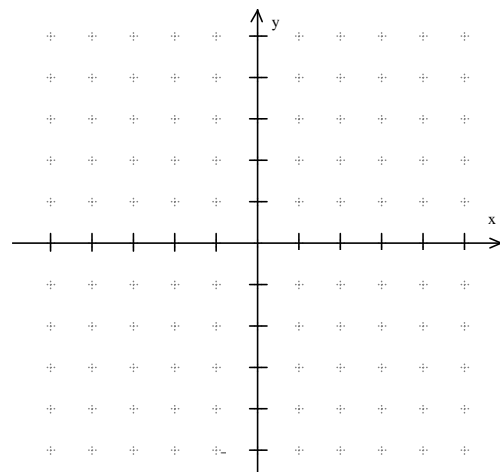

ALGEBRA BASIC SKILLS PRACTICE TEST

The test you will take on the first day of school is very similar to this test; however, it will be a multiple choice test. You are not expected to get 100%, but you should get most problems in each skill correct. Practice for this and you will start your year off right.

SKILL A1: Signed Numbers and Order of Operations

1. $-42 - 21 + 15$	2. $-6 - (-7)$	3. $\frac{2}{7} - \left(\frac{-12}{7}\right)$	4. $-5\frac{1}{3} + 6\frac{2}{3}$
5. $(-21) \div (-3)$	6. $-12 \cdot 5.2$	7. $\left(-\frac{3}{5}\right)\left(\frac{20}{9}\right)$	8. $\left(\frac{-3}{10}\right) \div \left(\frac{6}{15}\right)$

SKILL A2: Translating to Algebra

9. 3 less than 5 times a number	10. 2 more than the product of 5 and a number	11. 10 minus twice x
12. The product of 6 and x plus y	13. 4 times y is greater than 7	14. Mary has “q” pennies. If John has 2 more than twice the pennies Mary has, write an expression for how many pennies John has.

SKILL A3: Solving Linear Equations with Integral Coefficients.

SOLVE EACH EQUATION.

15. $x - 7 = -25$	16. $\frac{h}{2} = -6$
-------------------	------------------------

17. $4(3x+1) = -1$	18. $4(6-3h) = -3(2h-6)$
--------------------	--------------------------

SKILL A4: Monomial & Binomial Operations

SIMPLIFY:

19. $-2(4x - y) + y$	20. $(5x^4)^2$	21. $(3x^2)(2x^5)$
22. $5 - (x - 1)$	23. $(x + 5)(x - 2)$	24. $(2x + 1)(3x - 2)$

SKILL A5: Factoring

FACTOR THESE POLYNOMIALS COMPLETELY:

25. $18x - 12$	26. $4x^3 - x^2$	27. $6y^2 - 12y^3$	28. $a^2 - 36$
29. $x^2 + 7x + 12$		30. $x^2 - 7x - 18$	

SKILL 6: Graphing Linear Functions and Slope.

31. Find the slope of the line between $(3, -4)$ and $(-2, 9)$

32. Graph the line with y-intercept equal to -4 and slope $\frac{3}{2}$

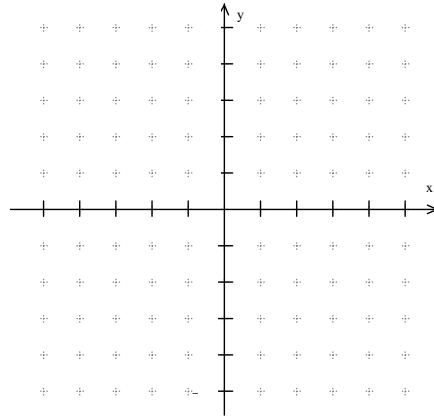

33. Graph using slope and y-intercept: $2x - 5y = 10$
Slope:

y-intercept

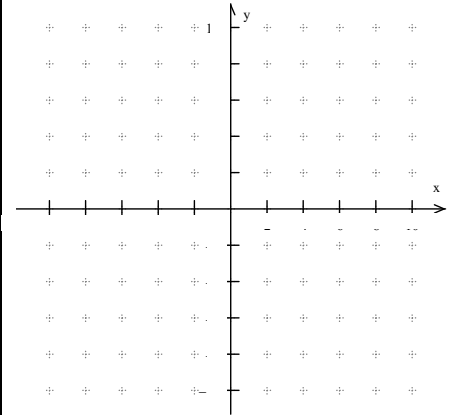

ANSWERS:

SKILL A1

1. -4	2. -8	3. 7	4. 2	5. -2	6. -5	7. -6	8. -2
9. 14	10. 3	11. 0	12. -7	13. -4	14. -48	15. 26	16. 1
17. 4	18. $\frac{-23}{15}$	19. -2	20. $\frac{31}{10}$	21. 0	22. \$3.75	23. 4.25	24. 30
25. -210	26. -45	27. 3	28. 5	29. -56	30. $\frac{1}{2}$	31. -16	32. 1.44
33. -60	34. 30	35. -38.4	36. $\frac{-2}{3}$	37. -5.15	38. $\frac{2}{5}$	39. $\frac{-5}{14}$	40. $\frac{-4}{5}$
41. $\frac{-16}{25}$	42. -48	43. $\frac{-5}{6}$	44. 8	45. 4	46. 0		

SKILL A2

1. $4 + n$	2. $7n$	3. $n - 3$	4. $2n$	5. $n - 6$	6. $n - 10$	7. $m + 3$	8. $2x$
9. $3 + y$	10. $4 + 3z$	11. $4n - 3$	12. $2n - 4$	13. $2x - y$	14. $\frac{x}{y}$	15. $\frac{x+y}{x-y}$	16. $2p - 1$
17. $S + 5$	18. $3R - 3$	19. $x + 2x = 45$		20. $2x = 12$		21. $n < 5$	

SKILL A3

1. 8	2. 23	3. 52	4. $\frac{1}{2}$	5. 3	6. 11	7. 8	8. 5
9. -3	10. 4	11. -4	12. 12	13. 6	14. 6	15. -6	16. -3
17. $\frac{-36}{7}$	18. 11	19. -18	20. $\frac{-14}{3}$	21. 5	22. 1	23. -7	24. -2
25. -2	26. 4	27. 33	28. 8	29. $\frac{47}{3}$	30. -8.2		

SKILL A4

1. $-3x^2 + 4x$	2. $-6y + 2x$	3. $x - 7y$	4. $4x^2 + 3x$
5. $8x^2 - 2x$	6. $7x^2 - 5x$	7. $-x - 5$	8. $-x - 3$
9. $3x - 13$	10. $2x^3 + 6x$	11. $3x^3 - 12x$	12. $4x^4 + 20x$
13. x^8	14. x^{15}	15. x^{28}	16. $9x^8$
17. $27x^9$	18. $16x^{20}$	19. $x^2 - 4$	20. $x^2 + 7x = 12$
21. $x^2 - 9x + 20$	22. $2x^2 + 11x + 12$	23. $3x^2 - 2x - 8$	24. $x^2 + 2x - 3$
25. $x^2 + 5x$	26. $6x^2 + 2x$	27. $2x - 7$	28. $3x^4 - 21x$
29. $x^2 + 6x + 9$	30. $27x^{12}$		

SKILL A5

1. $3(5x + 9)$	2. $2a(3a^3 - 10)$	3. $9(7z + 5)$	4. $3(4m - 3)$
5. $x^2(1 - x)$	6. $3a(4a^2 - 5)$	7. $-6x(3x + 1)$	8. $c(5 - c)$
9. $20g^2(4 - 3g^3)$	10. $2x^2(x^2 - 4x + 5)$	11. $15(5n - 2)$	12. $-12y(y^2 - 2)$
13. $4v(\sqrt{3} + 5\sqrt{2} - 3)$	14. $8x^2(4x + 1)$	15. $5x(2x + 10)$	16. $(x + 3)(x + 2)$
17. $(y + 3)(y + 6)$	18. $(a + 7)(a + 9)$	19. $(d - 12)(d - 1)$	20. $(w - 2)(w - 10)$
21. $(x + 6)(x + 5)$	22. $(x + 3)^2$	23. $(m + 8)(m - 7)$	24. $(z - 6)(x + 3)$
25. $(h - 8)(h + 2)$	26. $(k - 9)(k + 4)$	27. $(r + 5)(r - 2)$	28. $(g - 6)(g + 5)$
29. $(x - 7)(x + 7)$	30. $(a - 3)(a + 3)$		

SKILL A6

1. 6	2. -1	3. $\frac{3}{2}$	4. 1	5. -3	6. $\frac{1}{4}$	7. no slope	8. 0	9. $\frac{3}{5}$
------	-------	------------------	------	-------	------------------	-------------	------	------------------

<p>10.</p>	<p>11.</p>	<p>12. $m=3$, y-int. (0, 1)</p> <p>13.</p>
<p>14. $m = -\frac{1}{2}$, y-int. (0, 5)</p> <p>15.</p>	<p>16. $m = -\frac{3}{2}$, y-int. (0, 2)</p> <p>17.</p>	<p>18. $m = 3$, y-int. (0, 4)</p> <p>19.</p>

PRACTICE TEST

1. -48	2. 1	3. 2	4. $\frac{4}{3}$	5. 7	6. -62.4	7. $-\frac{4}{3}$	8. $-\frac{3}{4}$
9. $5x - 3$	10. $2 + 5x$	11. $2x - 10$	12. $6x + y$	13. $4y > 7$	14. $2q + 2$	15. -18	16. -12
17. $-\frac{5}{12}$	18. 1	19. $-8x + 3y$	20. $25x^8$	21. $6x^7$	22. $6 - x$	23. $x^2 + 3x - 10$	24. $6x^2 - x - 2$

25. $6(3x-2)$	26. $x^2(4x-1)$	27. $6y^2(1-2y)$	28. $(a+6)(a-6)$
29. $(x+4)(x+3)$	30. $(x-9)(x+2)$	31. $\frac{-13}{5}$	
32.	33. $m = \frac{2}{5}$, y-int. $(0-2)$		
